

(No Model.)

3 Sheets—Sheet 1.

W. J. HOGAN.
MANUFACTURE OF HARROW DISKS.

No. 383,882.

Patented June 5, 1888.

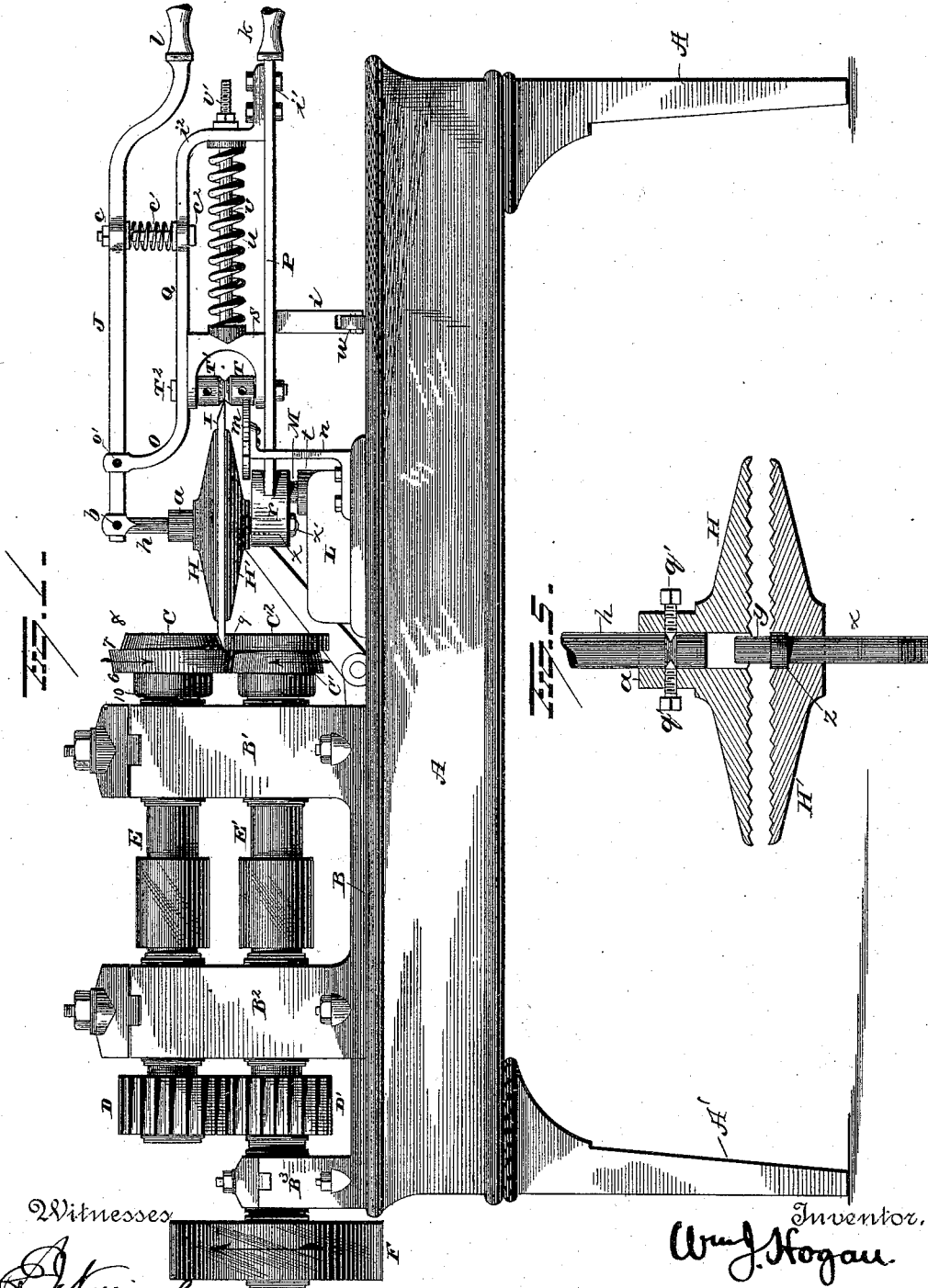

Witnesses

W. Nottingham
W. F. Downing

Inventor,

Wm. J. Hogan

By *his* Attorney
H. A. Seymour

(No Model.)

3 Sheets—Sheet 2.

W. J. HOGAN.
MANUFACTURE OF HARROW DISKS.

No. 383,882.

Patented June 5, 1888.

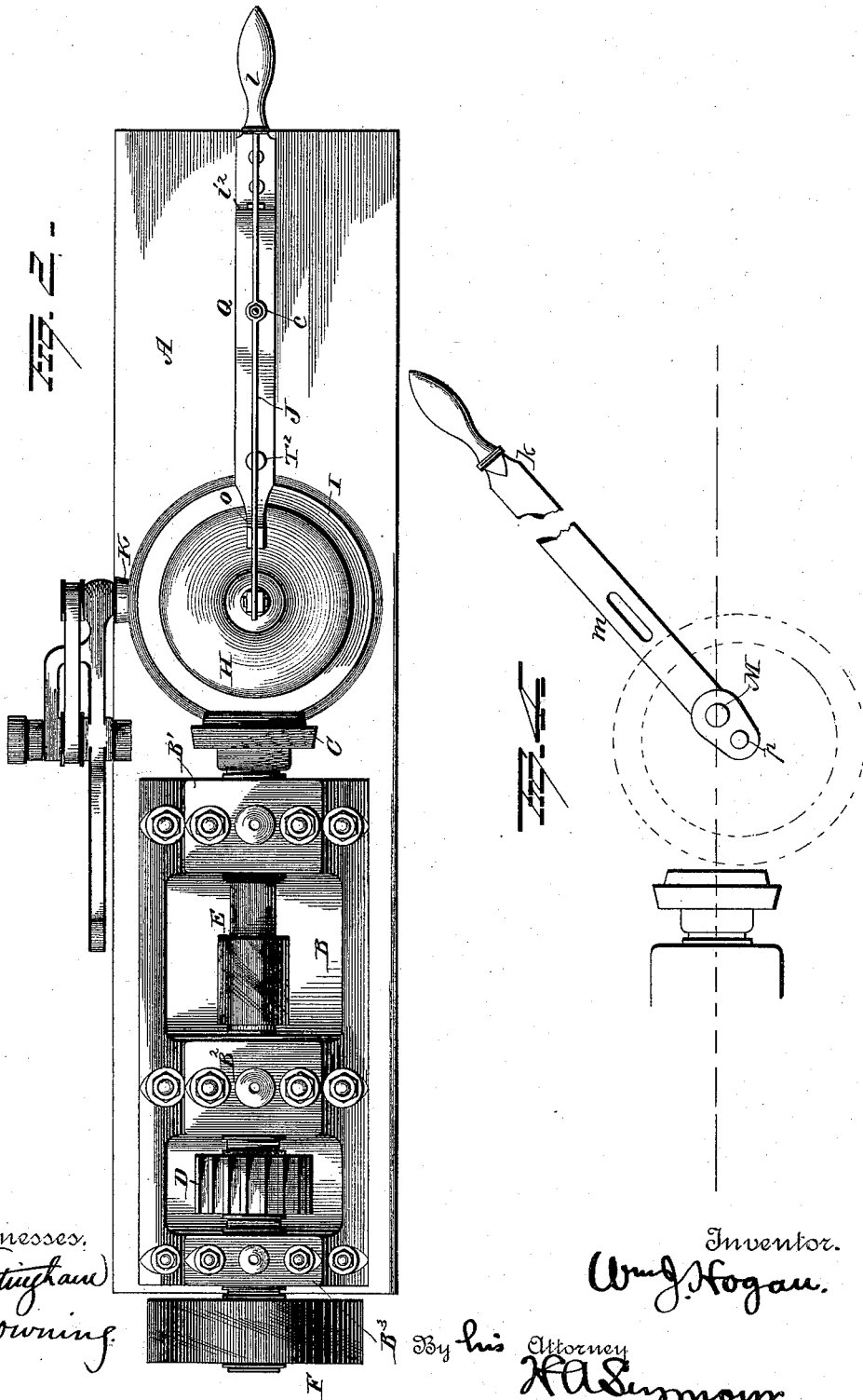

Witnesses.
W. Nottingham
G. F. Downing

Inventor.
W. J. Hogan.

By his Attorney
H. A. Seymour

(No Model.)

3 Sheets—Sheet 3.

W. J. HOGAN.
MANUFACTURE OF HARROW DISKS.

No. 383,882.

Patented June 5, 1888.

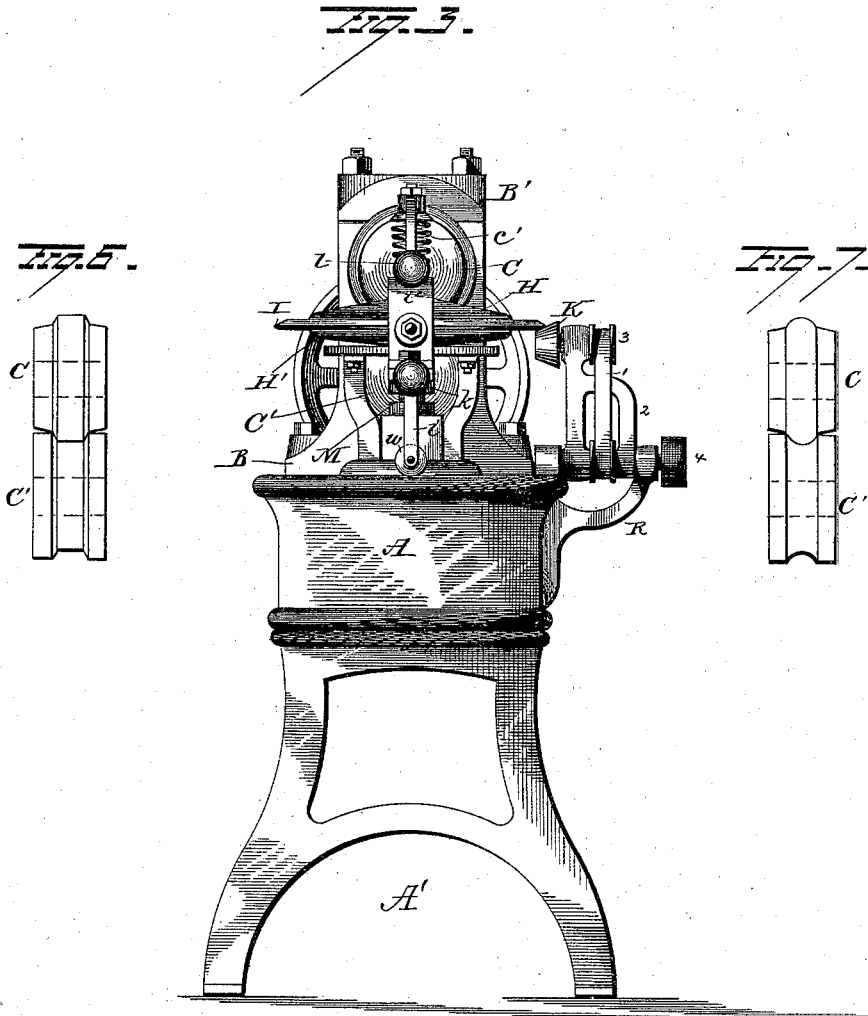

Witnesses,
E. Nottingham
G. F. Downing

Inventor,
Wm. J. Hogan

By his Attorney,
H. A. Sumner

UNITED STATES PATENT OFFICE.

WILLIAM J. HOGAN, OF JOHNSTOWN, PENNSYLVANIA, ASSIGNOR TO THE
CAMBRIA IRON COMPANY, OF PENNSYLVANIA.

MANUFACTURE OF HARROW-DISKS.

SPECIFICATION forming part of Letters Patent No. 333,882, dated June 5, 1888.

Application filed November 1, 1887. Serial No. 254,004. (No model.)

To all whom it may concern:

Be it known that I, WILLIAM J. HOGAN, of Johnstown, in the county of Cambria and State of Pennsylvania, have invented certain new and useful Improvements in the Process of Manufacture of Harrow-Disks; and I do hereby declare the following to be a full, clear, and exact description of the invention, such as will enable others skilled in the art to which it appertains to make and use the same.

My invention relates to an improved process for the manufacture of disks for harrows. In implements of this type a series of circular dished plates of metal are arranged to revolve upon central bearings, and these supporting-journals are so curved upon a hollow frame as to present the peripheral edges of the concavo-convex disks at a proper angle to the surface of the ground they are intended to pulverize to insure effective action of the same, the disks being intended to take the place of the teeth of an ordinary harrow.

In order to render the operation of the harrow-disks effective, it is necessary that their edges should be beveled to sharpen them, and it is important that these peripheral edges should be retained in a sharpened condition.

As heretofore constructed, the disks of harrows have been first cut into circular form from a flat plate of rolled metal in a cold condition. These circular blanks are then heated and dished, or rendered concavo-convex by placing them between dies in a drop-press or under a drop-hammer. They are then finished upon their edges cold by chucking them in a lathe to true up and bevel their edges, thus rendering them of the same diameter and sharpening them.

The method of manufacturing harrow-disks as just described involves machine-work that is slow of execution and therefore expensive. The finished disks are soft on their edges. Consequently they rapidly become dulled in use and are rendered comparatively inefficient in service.

The object of my present invention is to cheapen the cost of production of dished harrow-disks by more rapid production of the same, and also increase their operative effi-

ciency by a consolidation of material of the disks at their edges during the process of manufacture, which measureably hardens these sharpened edges and renders them more durable in use.

With these objects in view my invention consists in an improved process for the production of harrow-disks having their edges beveled and consolidated by rolling compression to sharpen them, and also render them durable.

Referring to the drawings, Figure 1 represents a side elevation, in perspective, of my improved machine for roll-swaging the circumference of the harrow-disks, to consolidate the metal and produce beveled sharp peripheral edges thereon. Fig. 2 is a plan view of the device for beveling the edges of hollow disks. Fig. 3 is an end elevation of the disk-swaging machine. Figs. 4 and 5 are detached views of important details. Figs. 6 and 7 are views in section of modified forms of rolls, showing different methods of constructing the same to afford a coniform terminal to one roll and lock the two rolls from lost motion endwise with regard to each other.

A represents the bed piece or frame of the machine, preferably made of cast-iron, rectangular in form, and provided with supporting-legs A', which are attached upon its under side at each end. Upon the top surface, at one end of the frame A, a head-stock, B, is affixed by bolt-connections. This consists of a base-plate, upon which are integrally mounted the upright brackets or housings B' B² B³. The main housings B' B² are of a suitable height and width, and are located a proper distance apart, so as to admit of the insertion and revoluble support of two shafts, E E', which latter are journaled in boxes adjustably secured in a manner to afford the shafts a correct separation and parallelism of their axes.

At the rear end of the head-stock B the bracket or housing B³ is located. This is of such a height as to admit a single journal-box, in which the rearwardly-extended end of the lower shaft, E', is supported and adapted to revolve when actuated by power applied through a belt-connection of the pulley F,

which latter is affixed to the end of the shaft E', projecting outside of the housing B³, as shown in Figs. 1 and 2.

Between the housings B² B³ two spur gear-wheels, D D', are located. These are mounted upon and secured to the shafts E E', respectively, and are of such diameter as to permit their teeth to have meshing contact. The other ends of the parallel shafts E E' are extended outside of the housing B' and give support to the short cylindrical rolls C C', which are firmly keyed or otherwise affixed in place upon these shafts, respectively, as named.

The top roll, C, is rendered true upon its outer surface, considered radially from the axis of the shaft E. This surface is diametrically enlarged near its center of length between the points 6 and 7, (see Fig. 1,) and from the point 7 to the outer end, 8, the peripheral surface is tapered or rendered slightly conical.

The body of the roll C between the shoulders 6 and 7 is tapered slightly toward the housing B', and from the shoulder 6, which is nearest this housing, the roll C is reduced to form a cylindrical hub, 10, which has revoluble contact with the housing-box to which it is adjacent.

The lower roll, C', is provided with a cylindrical portion, C², which is of the same length as the conically-tapered portion of the upper roll, C, opposite to it, so that the shoulder or square offset produced at the point 7 on these two rolls will have a rolling contact with each other.

From the point 7 to point 6 the lower roll, C', is oppositely tapered to exactly conform to the tapered surface of the upper roll, C, and from point 6 to the inner end of the roll C' the body of this roll is reduced to form a cylindrical hub similar to the hub 10 on the upper roll.

The revoluble contact of the tapered middle portions of the two rolls C C' and the moving abutment of the shoulders formed on these rolls at the point 7 will lock the rolls from lost motion en masse, and, owing to the outer tapered end of the roll C having contact with the cylindrical portion C² of the lower roll, C', at the point 9, it is apparent that a wedge-shaped opening will be afforded between the surfaces of the ends of the rolls.

Upon the top surface of the frame A of the machine, just in advance of the rolls C C', a saddle-block, L, is mounted and affixed in position. On the end *t* of this block a cylindrical enlargement is located, it forming the base of the vertically-projecting stud M.

The lever P is provided with an enlarged oblong boss, *r*, that is perforated vertically at its rear end, this hole being of proper diameter to admit the insertion of the stud M, upon which the lever P may be vibrated laterally. The lever P is furnished with a handle, *k*, at its free outer end, and also has a depending bracket-arm, *i*, formed integral with it, this arm *i* being bifurcated at its lower end to receive a small wheel, *w*, adapted to revolve

freely between the forked ends of the arm and rest upon the top surface of the bed-plate or frame A of the machine. A second perforation, *p*, (see Fig. 4,) is made vertically through the boss *r* parallel to the stud M and nearer the outer end of the boss *r*, the hole *p* being adapted to receive the standing bolt X, (see Fig. 1,) the hole being shown in dotted lines.

On the top surface of the boss *r* the lower plate of the mated clamping-flanges H H' is seated. A cross-section of these flanges taken through their center is shown in Fig. 5. It will be seen that the inner adjacent faces of the flanges H H' are grooved concentrically to reduce the surface of contact.

Both of the flanges are centrally perforated, and the lower one, H', is recessed or counter-bored from its top face downward a short distance to allow the collar *z*, formed integral with the standing bolt *x*, to seat itself in this recess. The length of the bolt *x* is so proportioned to the thickness of the flange H' and boss *r*, formed on the lever P, that when the parts are assembled and a nut, *x'*, adjusted upon the threaded lower end of the bolt *x*, so as to bear against the inner shouldered termination of this thread, the flange H' will be held in place, and yet be permitted to rotate freely upon the bolt *x* as a pivot.

The standing bolt *x* has an integral cylindrical end, *y*, formed on it, which projects vertically a short distance above the collar *z*. The central hole made in the top flange, H, is of a size to loosely fit the end *y* of the bolt *x*, so that a dowel-and-socket connection is thus produced between the top and bottom circular clamping-flanges, H H'.

Upon the surface of the lever P a bracket-arm, Q, is mounted. This arm is rigidly secured by bolts *i* to the lever near its handle *k*, and extends upwardly to a point, *i'*, where it is bent to lie parallel to the lever P and extend forwardly to a point, *o*, where it is again bent upwardly to engage with its bifurcated end *o'* the body of the handle-bar J.

The bar J extends forward from the end *o'* to be pivotally connected to the swivel-bolt *h*, that enters the central perforation of the top clamping-flange, H, which latter has a hub, *a*, formed on its top surface, that affords a means of connection to the bolt *h* by the insertion of two set-screws, *q' q'*, at opposite points through the side walls of the collar. Their ends will enter a groove formed in the swivel-bolt, and thus permit the flange H to revolve on the swivel-bolt, while it is prevented from vertical displacement, so that the vertical vibration of the handle-bar J upon its fulcrum *o'* will raise the top clamping-flange, H, and clear it from its engagement with the dowel-pin *y*. A handle, *l*, is provided for the bar J, and at a point, *e*, a spiral spring, *e'*, is introduced and held in place by a bolt, *e²*, the action of the spring having a tendency to raise the handle-bar J and clamp the top flange, H, upon the lower flange, H', or anything introduced between them.

Between the lever P and attached bracket Q a sliding block, *s*, is located. This is adapted to have a reciprocal movement on its seat, and at its rear edge the spring *u* is introduced, this spring encircling a bolt, *v*, that extends from the rear edge of the block *s* and passes through the vertical portion of the bracket Q, the projecting end *v'* being threaded to receive an adjusting-nut, by which the position of the sliding block *s* may be adjusted toward or from the clamping-flanges H H', as may be required. The body of the block *s* is cut away from the front edge to afford space for the introduction and support of the thimbles T T', which are placed upon the bolt T², and thus held loosely to permit their revolution thereon. The adjacent edges of the thimbles T T' are cut away slantingly to produce a V-shaped groove at their point of contact.

The relative height of the top face of the lower clamping-flange, H', from the supporting-surface of the frame A is such in relation to the line of contact between the two rolls C C' that this face will lie in the same horizontal plane with the top surface of the adjacent cylindrical end of the lower roll, C', as shown in Fig. 1.

By the provision just mentioned the lower clamping-flange, H', will retain a disk or blank clamped upon it in such a horizontal plane as to enter the edge of such a circular plate or disk, if of proper diameter, flatwise between the opposite surfaces of the end of the top and bottom rolls, C C'.

In operation a disk, I, that has been previously heated evenly throughout its body, is introduced between the clamping-flanges H H', these flanges having first been moved laterally, as shown in Fig. 5, to carry them out of axial line with the rolls C C', which will permit the upper flange to be raised by the handle-bar J.

The blank-disks I have a central perforation made through them of a proper diameter to permit them to fit the vertical dowel-pin *y*, which is the upper end of the standing bolt *x*, and on insertion of a disk between the clamping-flanges H H' the pin *y* is made to enter the hole in the center of the disk. A release of the handle-bar J will clamp the two flanges forcibly together by the expanding of the previously-compressed spring *c'*. The disk I is now in position, with its edge protruding concentric with the peripheries of the clamping-flanges H H'. Motion is now communicated to the pulley F, which is rotated in the direction indicated by the arrow on its face. (See Fig. 1.) The revolution of the lower shaft, E', and its attached roll C' will cause the upper shaft, E, and roll C to rotate with equal speed in an opposite direction, so that the rolls C C' move rapidly toward each other, as shown by arrows on these faces. The clamped harrow-disk I is now moved laterally by swinging the handle *k* of the lever P, and the edge and the narrow portion of the body of the disk is thus brought into contact

with the revolving rolls C C'. The position of the grooved thimbles T T' is such with regard to that of the clamped disk I that its edge will bear loosely within the V-groove formed on these thimbles at the apex of its angle, and the strength of the spring *u* is so proportioned that it will afford a proper support to the block S, and consequently to the revolving edge of the disk I when the machine is in operation. As the handle *k* is held by the operator to keep the edge of the disk I in proper contact with the revolving rolls C C', these rolls will speedily reduce the edge and cause it to conform to the wedge-shaped space between them, so as to bevel or taper the same to a thin sharp edge. A rapid rotation of the clamped harrow-disk I, resulting from the enforced introduction of its edge between the rolls, will render the thinned edge uniformly true.

The thinning of the edge of the harrow-disk I by the rolls C C' has a tendency to consolidate the same and partially cool it, and when the disk-edges are rolled to a finish the surface is chilled by the contact of the metal surfaces of these rolls, and a stiff scale is formed that will resist wear and render the disks more durable.

In order to remove the fin edges from the disks while they are being rolled, as just described, a vibrating forked arm, 2, is supported to rock upon the bracket R, which is affixed to the side of the frame A, (see Fig. 3,) and upon the upper end of the arm 2 a short shaft is revolubly mounted. This shaft has a tapering emery-wheel or grindstone, K, attached to its inner end in such a position as to come in contact with the lower side of the revolving disk I, the taper of the emery-wheel or stone K corresponding to the short bevel produced by the lower roll, C', upon the lower surface of the disk at its extreme edge. A rotation of the emery-wheel or stone K is effected by a pulley, 3, placed on the opposite end of the shaft on which the wheel K is mounted, and a belt, 1, transmits motion from a lower pulley-shaft mounted in the bracket R, and receives motion from some adequate source by means of belt attachment to the pulley 4, mounted on the outer end of the latter-named shaft.

The action of the emery-wheel K, it should be understood, is not intended to grind away any of the surface produced by the rolling compression and consolidation of the edges of the harrow-disks I, but merely to remove accidental inequalities and burrs produced thereon by the contact therewith of the re-enforce thimbles T T', these being necessary to relieve the center hole of strain and steady the action of the rolls.

The concentric grooving of the clamping-faces H H' affords a more secure bite of the plates upon the interposed disks I, and also by reducing the surface of contact of these faces with the hot disks will prevent an undue absorption of the contained heat of the disks while undergoing the edging process, so that

sufficient heat will remain in the body of the disk after removal from the edging-machine to allow them to be dished under a drop-hammer or in a press by suitable dies without a renewal of heat, as such a renewal would destroy the rolled temper given the edge of the disks, and thus vitiate the good results derived from the rolling consolidation of these edges in the manner hereinbefore set forth.

10 Having fully described my invention, what I claim as new, and desire to secure by Letters Patent, is—

15 1. The process of manufacturing dished disks for harrows, consisting in heating circular flat blanks of sheet metal, then placing them in a proper machine and rolling their edges so as to consolidate the material and bevel them to a thin edge, which is thus rendered measurably hard by rolling compression and contact of metallic surface therewith, then removing the disks from the edging-machine, and dishing them in a drop-press or drop-hammer in dies, substantially as set forth.

25 2. The process of manufacturing dished disks for harrows, consisting in first shearing or otherwise cutting circular flat blanks from unheated plate metal, then heating these blanks, and in a proper machine rolling their edges to bevel, sharpen, and consolidate the material and semi-harden these edges, and finally removing the disks from the edging-machine and

giving them a concavo-convex form in dies under a hammer or press, substantially as set forth.

35 3. The process of manufacturing dished disks for harrows, consisting in first shearing or otherwise cutting circular flat blanks from cold sheet metal, then heating the blanks and subjecting their edges to a rolling pressure in a proper machine to bevel, sharpen, and semi-harden these edges by consolidation of their atoms and metallic contact of the rolls of the machine, at the same time removing the slight inequalities of the edges by proper means, and finally removing the disks from the edging-machine and drop-pressing them in dies to give them a dished form, substantially as set forth.

40 4. The process of manufacturing harrow-disks, consisting in heating flat blanks of metal and beveling their edges by rolling, substantially as set forth.

50 5. The process of manufacturing harrow-disks, consisting in heating flat blanks of metal, then beveling their edges by rolling, and finally dishing said blanks, substantially as set forth.

55 In testimony whereof I have signed this specification in the presence of two subscribing witnesses.

WILLIAM J. HOGAN.

Witnesses:

JOHN McDERMOTT,
JAS. H. LARKIN.